

(Fig.1)

1. Remove the 4 foremost lid-to-base self tapping retaining screws (No.4 x 1/4), located on the sides of the PDA unit (marked as 'A' on Fig.1). Remove the two screws holding the front 'bumper feet' (marked as 'B') if these have been fitted. Do not remove the rearmost screws on the side or rear of the unit.

2. Position the PDA unit so that the front face is flush with the front of the mounting plate and the 4 vertical fixing holes (2 each side) line up with the vacant lid-to-base retaining screw holes on the side of the PDA unit.

3. Refit the 4 off No.4 x 1/4 self tapping screws ('A') through the mounting plate holes and into the PDA unit side holes then tighten. (See Fig. 2) Note: Do not fully tighten these screws until step 4 has been completed as this will make alignment of the 'B' holes with the M3 machine screws, in step 4, easier).

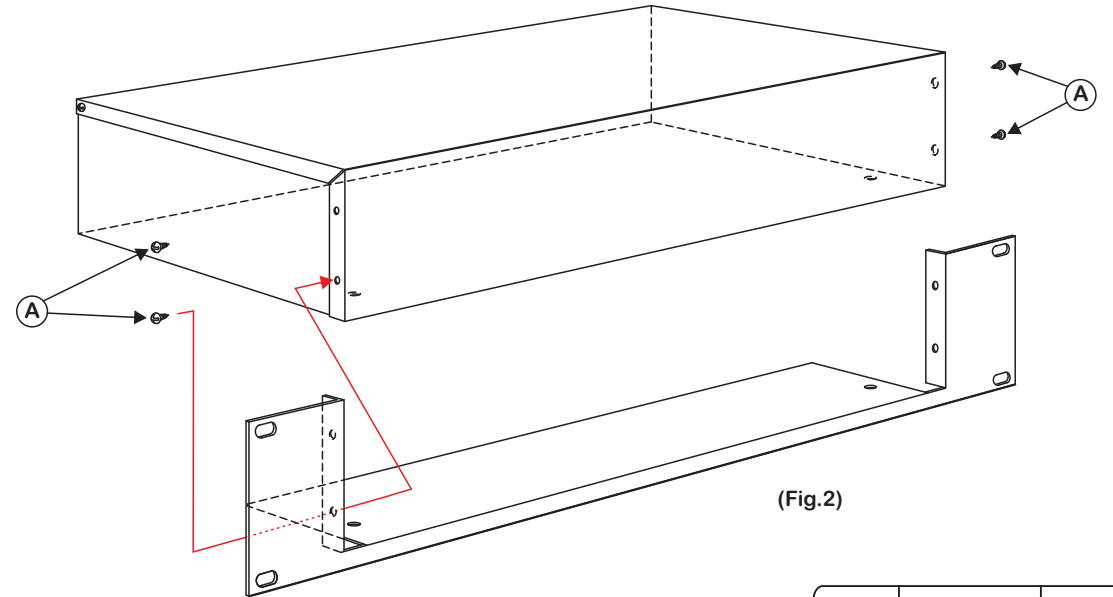

(Fig.2)

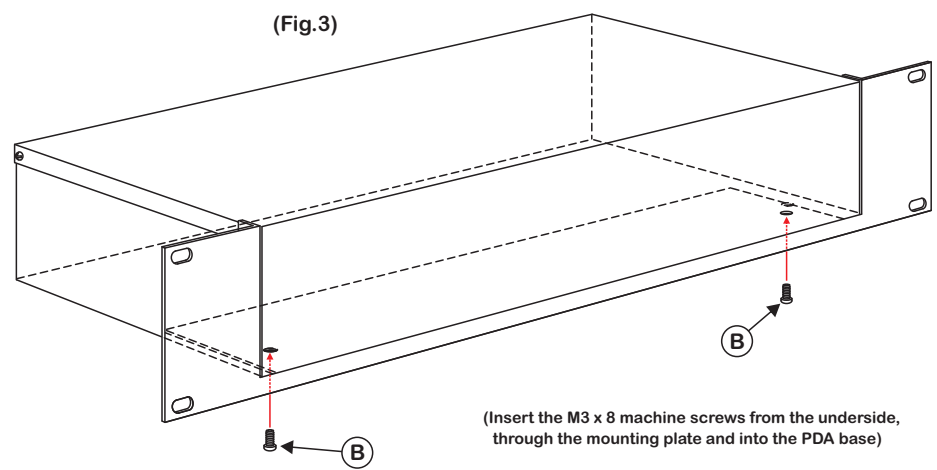

(Fig.3)

(Insert the M3 x 8 machine screws from the underside, through the mounting plate and into the PDA base)

4. Using the M3 x 8 machine screws provided, fasten the bottom of the mounting plate to the underside of the PDA unit base by screwing the M3 screws through the mounting plate and into the two front 'bumper feet' fixing holes (shown as 'B' in Fig.3). Tighten ALL the screws fully.

NOTE: This mounting kit uses the PDA unit as a 'Stressed Member' so all fixings (case & rack) **MUST** be tightened fully. Under no circumstances should any 'weight' be placed on top of the assembly when fitted into a rack otherwise the mounting bracket may bend.

Rev. No.	NCR No.	Date

Dwg. No.	DCP 0003419	
Title	PDA Range Rack Mount Kit	
	Fitting Instructions	
Revision	0	Date 17/1/06
Drawn By	JSL Software	Corel V13
Sheet	1	of 1